

NOTES: UNLESS OTHERWISE SPECIFIED

- 1 LUBRICATE O-RING WITH PARKER SUPER-O-LUB OR EQUIV.
- 2 INSTALL SCREW WITH LOCTITE #425 OR EQUIV.
- 3 INSTALL SCREW WITH PERMA-LOK LM113 OR EQUIV. AND TORQUE 13 TO 15 IN.-LBS.
- 4 LUBRICATE BORE WITH A LIGHT COAT OF PARKER SUPER-O-LUB OR EQUIV.
5. APPROXIMATE WEIGHT 1.4 LBS.
6. APPROXIMATE LENGTH 10 INCHES.
- 7 ITEM 37 CONSISTS OF ITEMS 17-22, 27, 32 AND 34.
- 8 PRIOR TO SECURING ITEM 38 (HOSE ASSEMBLY) TO ITEM 1 (BODY) APPLY TEFLON TAPE TO NPT THREADS.
- 9 LIGHTLY LUBRICATE THREADS WITH KRYTOX GPL-200 GREASE OR EQUIV.

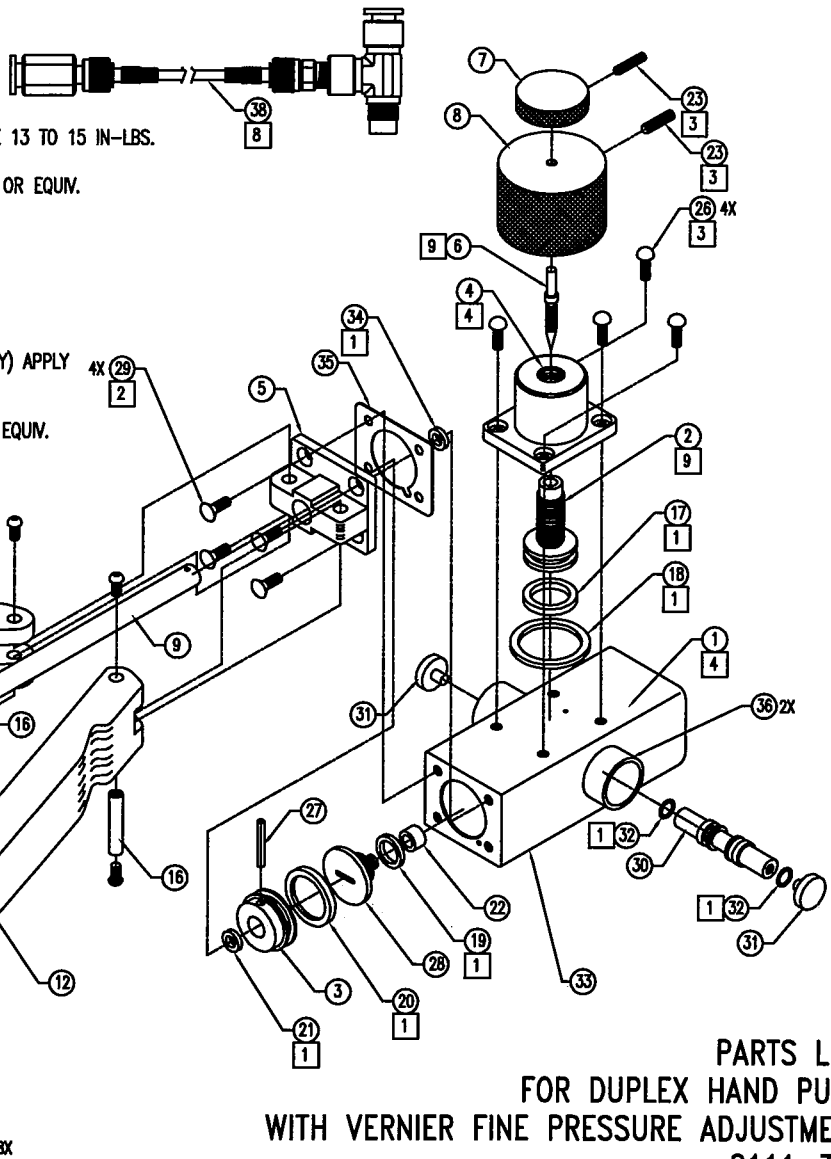

**PARTS LIST
FOR DUPLEX HAND PUMP
WITH VERNIER FINE PRESSURE ADJUSTMENT
8111-300**

ITEM	PART NO.	QTY.	DESCRIPTION
1	2016-0010	1	BODY, MACHINED PNEUMATIC HAND PUMP
2	2136-0015	1	PISTON, VERNIER PNEUMATIC HAND PUMP
3	2136-0014	1	PISTON, BODY PNEUMATIC HAND PUMP
4	2011-0004	1	BASE, VERNIER PNEUMATIC HAND PUMP
5	2011-0006-1	1	BASE, BODY PNEUMATIC HAND PUMP
6	2190-0022	1	VALVE, NEEDLE
7	2105-0013	1	KNOB, NEEDLE RELIEF VALVE PNEUMATIC HAND PUMP
8	2105-0012	1	KNOB, VERNIER PNEUMATIC HAND PUMP
9	2155-0031	1	SHAFT, PNEUMATIC HAND PUMP
10	2161-0126-1	1	SPRING, RETURN
11	2205-0001	1	YOKE, MACHINED PNEUMATIC HAND PUMP
12	2084-0003-1	2	HANDLE, UNIVERSAL, HAND PUMP
13	2112-0003	2	LINK, PNEUMATIC HAND PUMP
14	2135-0077-1	1	PIN, PIVOT
15	2135-0077-2	2	PIN, PIVOT
16	2135-0077-3	2	PIN, PIVOT
17	2128-0001-36	1	O-RING, SIZE 2-113
18	2128-0001-35	1	O-RING, SIZE 2-021
19	2128-0001-34	1	O-RING, SIZE 3-904

ITEM	PART NO.	QTY.	DESCRIPTION
20	2128-0001-33	1	O-RING, SIZE 2-115
21	2128-0001-25	1	O-RING, SIZE 2-008
22	2152-0054	1	SEAL, VALVE
23	2154-0001-69	2	SCREW, SET 8-32 X .38 LG
24			
25	2154-0001-46	10	SCREW, BUTTON HD 6-32 X 1/4 LG
26	2154-0001-65	4	SCREW, PAN HD 6-32 X .38 LG
27	2135-0076-1	1	PIN, SPRING 3/32 X 3/4
28	2190-0021	1	VALVE PLUG PNEUMATIC HAND PUMP
29	2154-0001-68	4	SCREW, 100° CSK HD 6-32 X .38 LG
30	2170-0100	1	SPOOL, DUPLEX HAND PUMP
31	2105-0014	2	KNOB, SHUTTLE DUPLEX HAND PUMP
32			
33	2124-0200	1	IDENTIFICATION LABEL
34	2128-0001-27	1	O-RING, SIZE 2-011
35	2074-0017	1	GASKET, BASE DUPLEX HAND PUMP
36	2038-0060	2	GUARD
37	8111-0301	1	SPARE PARTS KIT [7]
38	4086-0017	1	HOSE ASSEMBLY

8111-300
PNEUMATIC HANDPUMP
With Vernier Fine Pressure Adjustment

The 3D Hand-Operated Calibration Unit is a compact, lightweight and portable hand-operated pressure and vacuum source. When a 3D pressure gauge or Accu-Cal Plus Digital Gauge is added, the unit can be used to calibrate or check pressure measuring devices in the field. The Calibration units are safe: no external power or high pressure bottles are required. The units are completely assembled and ready to connect to the pressure device to be calibrated. Calibration is quick and simple because the handpump is taken to the pressure device rather than vice-versa. The units can be supplied with or without a 3D ¼% accuracy gauge or Accu-Cal Plus Digital Gauge. Refer to gauge ordering information.

OPERATING INSTRUCTIONS

The 8111-300 Duplex Handpump provides a source of air pressure: 0-300 psig or vacuum: 0-25 In. Hg.

1. Isolate device to be calibrated. **CAUTION:** *Avoid connecting to high pressure sources.* These precautions and safe operating procedures must be observed to avoid damage to the unit or personal injury. Connect the ¼" NPTF adapter and hose to the pressure device to be calibrated. Make sure connection is pressure-tight to prevent leakage.
2. Turn knurled knob on the needle valve (item 7) clockwise to close. **NOTE: HAND TIGHTEN ONLY** to prevent damage to the valve seat.
3. Set the shuttle valve (item 30) to "pressure" or "vacuum".
4. Squeeze the handles (item 12) until desired, or close to desired pressure is obtained. Additional force is required as the pressure is increased.
5. The pressure can be decreased with the needle valve (item 7).
6. The pressure can be "fine tuned" with the vernier knob (item 8). To increase pressure, turn the vernier knob clockwise and counterclockwise to decrease pressure. **Note:** the vacuum reading increases when the vernier knob is turned counterclockwise.
7. When calibration procedure is completed, bleed the pressure before disconnecting unit to prevent personal injury.
8. Store unit in a Handy-Cal carrying case or safe location.

TROUBLE SHOOTING

1. **If the desired pressure can't be reached or maintained:**
 - a. Check to ensure the needle valve (item 7) is closed.
 - b. Check all connections for leaks.
2. **If the pressure fails to increase when the handles (item 12) are squeezed and there are no leaks:**
 - a. Remove screws (item 25) and the pins (item 16) from the handle (item 12) where it attaches to the base (item 5).
 - b. Remove screws (item 29) and the base (item 5) with the associated hardware still attached.
 - c. Remove screws (item 25) from the yoke (item 11). Compress the spring (item 10) and unscrew the yoke (item 11) and relieve the spring (item 10).
 - d. Remove pin (item 27) and inspect the o-rings (items 20, 21 & 34) for damage. Replace the o-rings if damaged and replace the pin (item 27) with a new pin.
 - e. Check the operation of the piston (item 3) and the shaft (item 9). Pull the piston (item 3) and the shaft (item 9) in opposite directions and the pin (item 27) should contact the hole in the piston (item 3). Push the piston (item 3) and the shaft together and the pin (item 27) should not contact the hole in the piston (item 3). Replace the piston (item 3) if the check is not met.
 - f. Remove knob (item 31), note screw thread, and remove the spool (item 30). Inspect the o-rings (item 32) for damage. Replace the o-rings if damaged.
 - g. Reassemble using the instructions found in the notes..
3. **If the pressure rises when the handles are squeezed but decreases when the handles are released:**
 - a. Remove screws (item 25) and the pins (item 16) from the handle (item 12) where it attaches to the base (item 5).
 - b. Remove screws (item 29) and the base (item 5) with associated hardware still attached.
 - c. Remove the valve plug (item 28) and inspect the o-ring (item 19) and seal (item 22) for damage. Replace if damaged.
 - d. Reassemble using the instruction found in the notes.
4. **If the handles fail to open when relieved:**
 - a. Check all of the pins (items 14, 15 & 16) for free action. Adjust and re-lock the screws (items 25) per the notes.
5. **If it is difficult to obtain a full stroke with handles:**
 - a. Remove screws (item 25) and the pins (item 16) from the handle (item 12) where it attaches to the base (item 5).
 - b. Remove screws (item 29) and the base (item 5) with the associated hardware still attached.
 - c. Inspect the piston (item 3), and body bore (item 1) and the shaft hole in the base (item 5). Replace worn or damaged parts.
 - d. Reassemble using the instructions found in the notes.

3D Instruments, LLC
2900 E. White Star Avenue, Anaheim, California 92806 USA
Phone: (714) 399-9200 Fax: (714) 399-9221
Internet: <http://www.3dinstruments.com> E-mail: info@3dinstruments.com